



Fastener  
Solutions

# 28" Heavy Duty Cable Ties Marketing Specifications

For the following part numbers:

10618-0

10619-0

10620-0

August 1, 2018

# AVERY DENNISON MARKETING SPECIFICATION

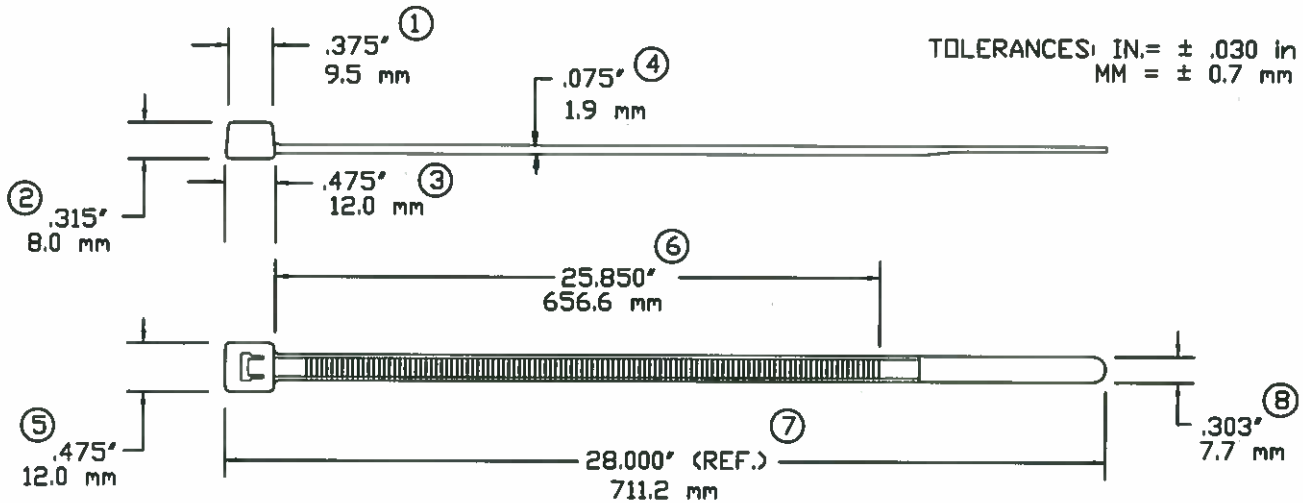

**NOT TO SCALE**

LOOP TENSILE STRENGTH:	120 LBF / 534N MINIMUM PER AS-23190
OPERATING TEMPERATURE:	-40°F(-40°C) TO 185°F(85°C)
MIN. INSTALLATION TEMP:	32°F(0°C)
MATERIAL:	NYLON 6/6
WEIGHT:	.377 oz. / 10.68 grams
MILITARY STANDARD:	MS-3367-6-9
BUNDLE DIAMETER:	Ø.250"/4.76mm TO Ø8.0"/203.2mm
TOOL TENSION SETTING:	6-8 ON HEAVY DUTY TOOL
PACKAGED IN:	50/BAG, 1,000/CASE

NOTE: THESE CABLE TIES ARE PLENUM RATED AND HAVE A FLAMMABILITY RATING OF V-2.



FASTENER DIVISION  
 FITCHBURG, MA 01420 U.S.A.  
 TEL. 1-800-225-5913  
 FAX. 1-800-848-2189



DESCRIPTION:

28" / 711mm CABLE TIE, HEAVY DUTY  
 NATURAL

APPROVAL:

*J. Boyle 9-15-2015*

STOCK NO.  
 10618-0

REV  
 F

# AVERY DENNISON MARKETING SPECIFICATION

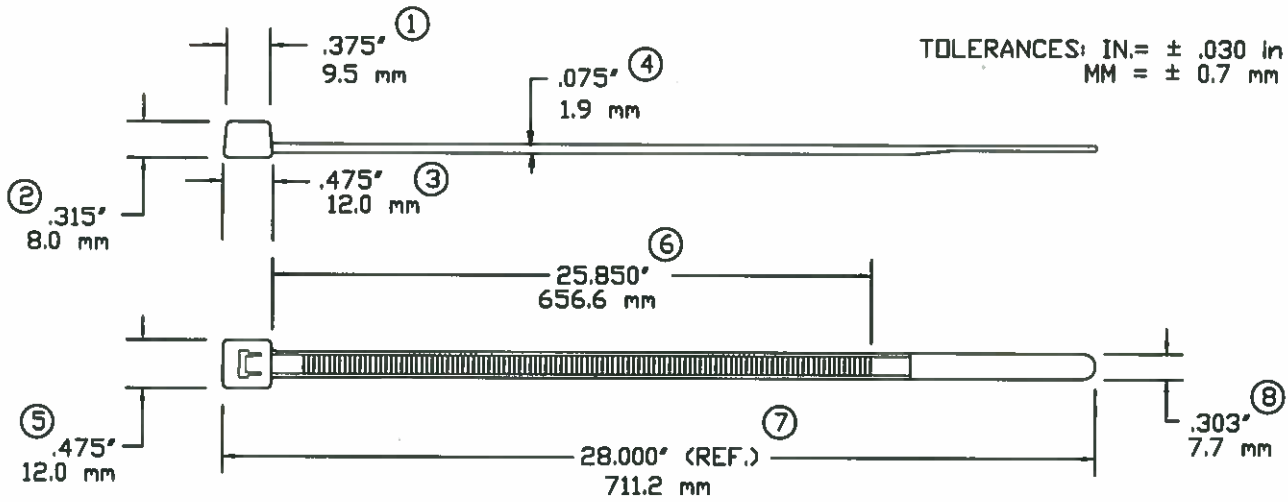

**NOT TO SCALE**

LOOP TENSILE STRENGTH:	120 LBF / 534N MINIMUM PER AS-23190
OPERATING TEMPERATURE:	-40°F(-40°C) TO 221°F(105°C)
MIN. INSTALLATION TEMP:	32°F(0°C)
MATERIAL:	NYLON 6/6
WEIGHT:	.377 oz. / 10.68 grams
BUNDLE DIAMETER:	ø.250"/4.76mm TO ø8.0"/203.2mm
TOOL TENSION SETTING:	6-8 ON HEAVY DUTY TOOL
PACKAGED IN:	50/BAG, 1,000/CASE

NOTE: THESE CABLE TIES ARE PLENUM RATED AND HAVE A FLAMMABILITY RATING OF V-2.



FASTENER DIVISION  
FITCHBURG, MA 01420 U.S.A.  
TEL. 1-800-225-5913  
FAX. 1-800-848-2169



DESCRIPTION:

28" / 711mm CABLE TIE, HEAVY DUTY  
BLACK HEAT STABILIZED

APPROVAL:

*J. Boyle 9-15-2015*

STOCK NO.

10619-0

REV

F

# AVERY DENNISON MARKETING SPECIFICATION

## HISTORY

THE SUBJECT MATTER DISCLOSED HEREIN EMBODIES PROPRIETARY INFORMATION WHICH IS THE CONFIDENTIAL PROPERTY OF THE AVERY DENNISON CO. NONE OF WHICH SHALL BE COPIED, REPRODUCED, DISCLOSED TO OTHERS, PUBLISHED OR USED IN WHOLE OR IN PART, FOR ANY PURPOSE OTHER THAN THAT FOR WHICH IT IS BEING MADE AVAILABLE, WITHOUT THE EXPRESS ADVANCE WRITTEN PERMISSION OF A DULY AUTHORIZED AGENT OF THE COMPANY. THIS DOCUMENT IS THE PROPERTY OF THE AVERY DENNISON CO. AND IS TO BE RETURNED TO THE COMPANY ON DEMAND.

REV.	DATE	DESCRIPTION
G	02.09.18	UPDATED TO NEW FORMAT; MADE HEAD TO FIRST TOOTH DIM A REF.

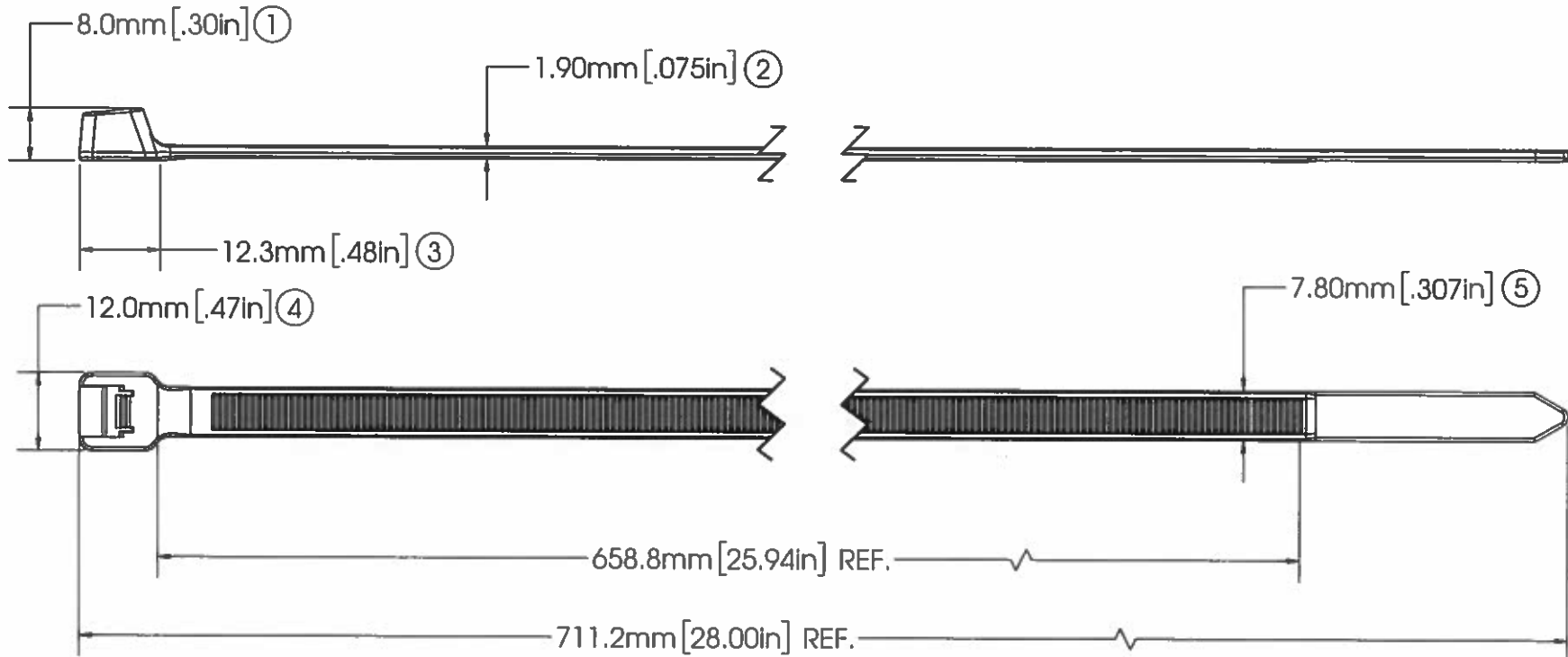

NOTES:  
1. SPECIAL CHARACTERISTICS ARE NOTED BY A TRIANGLE ( Δ )



Δ TENSILE STRENGTH:	120 LBF / 534N MIN.
Δ FLAMMABILITY RATING:	FMVSS302 AND V-2
MIN. INSTALLATION TEMP:	32°F (0°C)
MILITARY STANDARD:	MS-3367-6-0
OPERATING TEMP RANGE:	-40°F (-40°C) TO 176°F (80°C)
WEIGHT:	10.7g
BUNDLE DIAMETER:	∅6.4mm/.25in TO ∅203.1mm/8.00in
TOOL:	12001 - HAND INSTALLATION TOOL 12500 - PNEUM. INSTALLATION TOOL
TOOL TENSION SETTING:	6 - 8 ON A HEAVY DUTY TOOL
PACKAGING:	50/BAG, 1000/CASE

APPROVALS:	ENG. APPR. <i>[Signature]</i> 2/12/18
	Q.A. APPR. <i>Caitlin Villancourt</i> 2/12/18

SPECIFIED TOLERANCES ARE:		MATERIAL
.XX ± .03 IN.	.X ± .7mm	NYLON 6/6, WEATHER RESISTANT
.XXX ± .010 IN.	.XX ± .25mm	COLOR
ANGULAR: ± 2°		<b>BLACK</b>

<b>AVERY DENNISON</b> <small>FASTENER DIVISION FITCHBURG, MA 01420 U.S.A. TEL. 1-800-225-5913 FAX. 978-353-8157</small>	DESCRIPTION	<b>CABLE TIE, HEAVY DUTY, 28" (711mm)</b>
	STOCK NO.	<b>10620-0</b>
REV.	<b>G</b>	

5

4

3

2

1